

**DIMENSIONI D'INGOMBRO / OVERALL DIMENSIONS / ENCOMBREMENT / BAUMASSE / DIMENSIONES MAXIMAS
FORMA B3 - B14 / B3 - B14 FORM / FORME B3 - B14 / FORM B3 - B14 / FORMA B3 - B14**

dimensions in mm

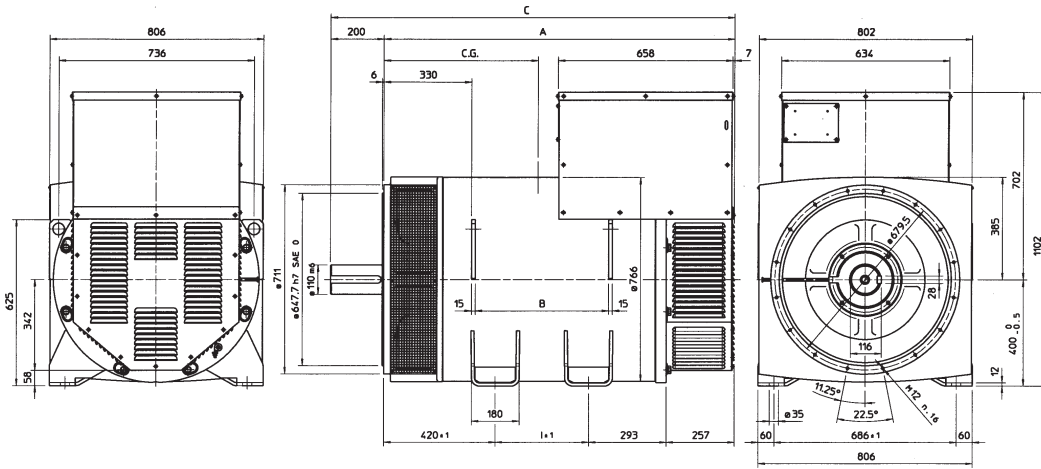

TIPO/TYPE/TYPE/TYP/TIPO	A	B	C	I
ECO 43 - S N	1320	500	1520	350
ECO 43 - L N	1520	700	1720	550

TIPO/TYPE/TYPE/TYP/TIPO	C.G.
ECO 43 - 1SN/4	590
ECO 43 - 2SN/4	620
ECO 43 - 1LN/4	720
ECO 43 - 2LN/4	810

**DIMENSIONI D'INGOMBRO / OVERALL DIMENSIONS / ENCOMBREMENT / BAUMASSE / DIMENSIONES MAXIMAS
FORMA MD35 / MD35 FORM / FORME MD35 / FORM MD35 / FORMA MD35**

dimensions in mm

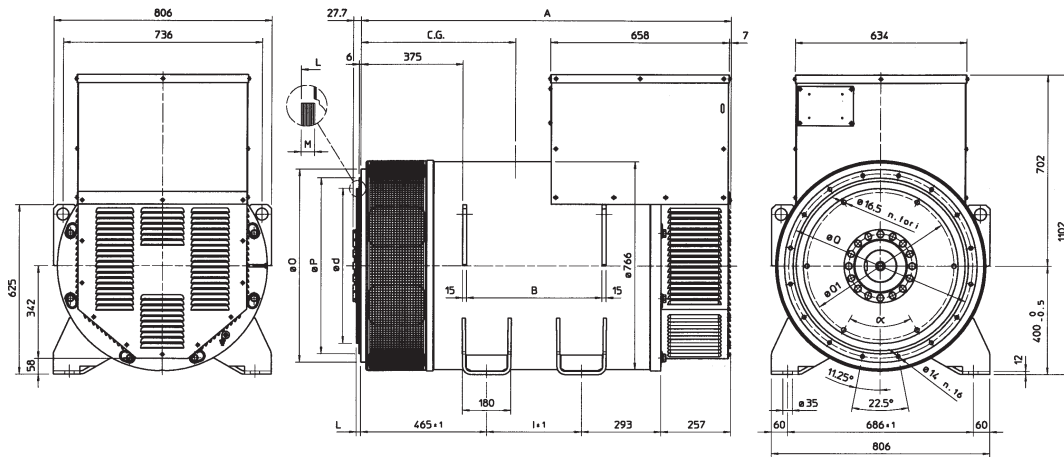

TIPO/TYPE/TYPE/TYP/TIPO	A	B	I
ECO 43 - S N	1365	500	350
ECO 43 - L N	1565	700	550

SAE N.	FLANGIA/FLANGE/BRIDE/FLANSCH		
	O	P	Q
1	711	511,2	530,2
0	711	647,7	679,5
00	883	787,4	850,9

SAE N.	GIUNTI A DISCHI/DISC COUPLING/DISQUE DE MONOPALIER/SCHIEBENKUPPLUNG					
	d	L	M	Q1	N. FORI	∠
18	571,5	15,7	10	542,92	6	60°
21	673,1	0	12	641,35	12	30°

TIPO/TYPE/TYPE/TYP/TIPO	C.G.
ECO 43 - 1SN/4	510
ECO 43 - 2SN/4	570
ECO 43 - 1LN/4	660
ECO 43 - 2LN/4	770

**ALTERNATORE SERIE ECO43N/4 - ELENCO PARTI DI RICAMBIO / ALTERNATOR SERIES ECO43N/4 - LIST OF SPARE PARTS
ALTERNATEUR SERIE ECO43N/4 - LISTE DES PIÈCES DÉTACHÉES / GENERATOR SERIE ECO43N/4 - ERSATZTEILLISTE
ALTERNADOR SERIE ECO43N/4 - LISTA PARTES DE REPUESTO**

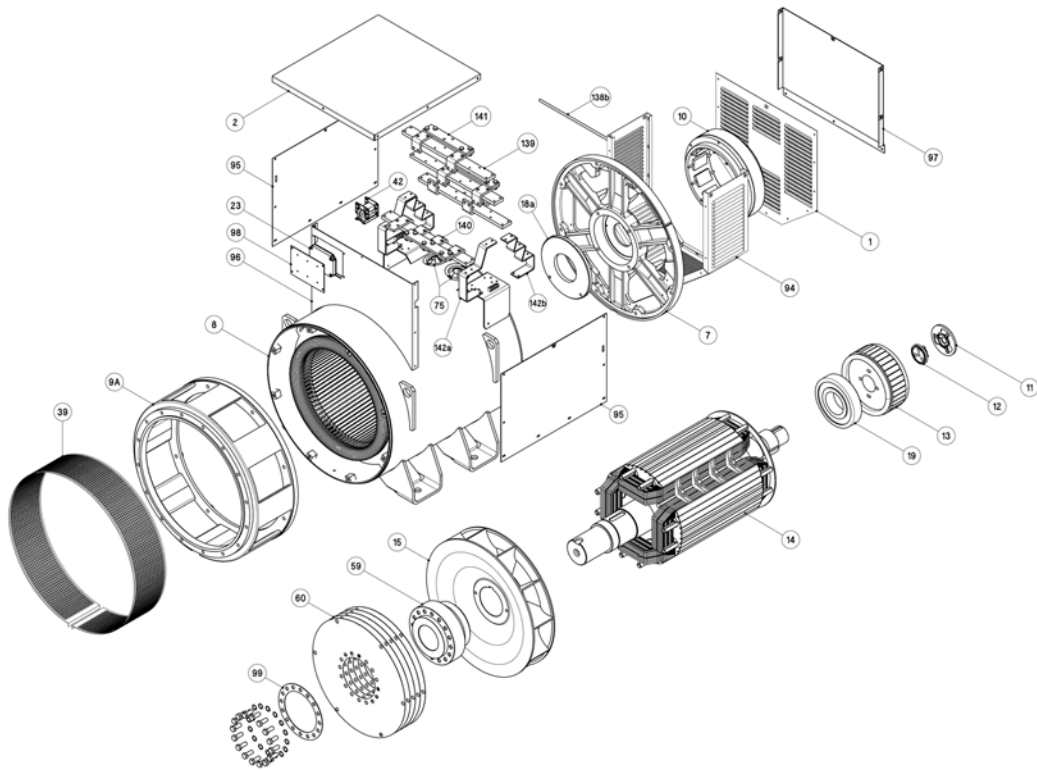

N.	DENOMINAZIONE	NAME	DESIGNATION	NAMEN	DENOMINACION	CODICE/CODE
1	chiusura posteriore	rear seal	tole de fermeture arriere	hinterer deckel	cierre posterior	9903905805
2	cuffia	terminal box lid	couvercle	klemmenkastendecker	tapa	9903905801
7	coperchio posteriore	non drive end bracket	flasque arriere	hinterer gehause	tapa posterior	6102306092
8	carcassa con statore	frame and stator	carcasse avec stator	gehause mit stator	carcaza con estator	4501201***
9A	coperchio anteriore MD35 SAE 0	drive end bracket SAE 0	flasque avant SAE 0	vorder gehause SAE 0	tapa anterior SAE 0	6102312484
9B	coperchio anteriore MD35 SAE 00	drive end bracket SAE 00	flasque avant SAE 00	vorder gehause SAE 00	tapa anterior SAE 00	6102312483
9C	coperchio anteriore B34	drive end bracket B34	flasque avant B34	vorder gehause B34	tapa anterior B34	6102312482
9D	coperchio anteriore MD35 SAE1	drive end bracket SAE1	flasque avant SAE1	vorder gehause SAE1	tapa anterior SAE1	6102312485
10	statore eccitatrice	exciter stator	stator excitatrice	erregerstator	estator excitatriz	4500486550
11	ponte diodi rotante	rotating diode	pont de diode tournant	rotierende diodenbrueche	punte diodos giratorios	6101001001
12	mozzo bloccaggio eccitatrice	hub	bague	nabe	cubo	7502225150
13	rotore eccitatrice	rotating inductor	rotor d'excitatrice	erreganker	inducido excitatriz	4500568260
14	induttore rotante	rotor assy	roue polaire	rotor	inducido rotante	2001067***
15	ventola	fan	ventilateur	lufferrad	ventilador	6102217375
16	flangia ant. esterna	external front flange	bride de fixation du roulement flasque avant	externer vorderer flansch	brida anterior externa	6102315305
17	cuscinetto anteriore	front bearing	roulement avant	vorderes lager	cojinete anterior	9900908035
18A	flangia post. interna	inner posterior flange	bride arriere du roulement du flasque arriere	innerer hinterer flansch	brida posterior interna	8500604025
18B	flangia ant. interna	inner front flange	bride avant du roulement du flasque avant	innerer vorderer flansch	brida anterior interna	6102315310
19	cuscinetto posteriore	rear bearing	roulement arriere	hinterer lager	cojinete posterior	9900901122
23	regolatore elettronico UVR6/1-F	UVR6/1-F electronic regulator	regulateur electronique UVR6/1-F	UVR6/1-F elektronischer regler	regulador electronico UVR6/1-F	4505005121
39A	retina di protezione monosupporto	protection screen MD35 form	grille de protection forme MD35	schutzgitter form MD35	rejilla de proteccion forma MD35	8500626405
39B	retina di protezione bisupporto	protection board screen B34 form	grille de protection forme B34	schutzgitter form B34	rejilla de proteccion forma B34	8500626402
42	dispositivo di parallelo	parallel device	dispositif de mise en parallele	statikwandler	dispositivo de paralelo	4501090050
59A	mozzo portadischi volano 21	coupling hub flies 21	manchon porte disques mouches 21	nabe fliegen 21	cubo portadiscos moscas 21	6102335601
59B	mozzo portadischi volano 18	coupling hub flies 18	manchon porte disques mouches 18	nabe fliegen 18	cubo portadiscos moscas 18	6102335600
60	dischi SAE 21	disc plates SAE 21	disques SAE 21	kupplungsscheiben SAE 21	discos SAE 21	6110611070
	dischi SAE 18	disc plates SAE 18	disques SAE 18	kupplungsscheiben SAE 18	discos SAE 18	6110611060
75	gommino passacavo	cable grommet	passe cable en caoutchouc	gummi auge	goma pasacables	9909509095
94	carter posteriore	rear case	carter arriere	hinteres gehause	carter posterior	9903905806
95	pannello lat. scatola morsettiera	terminal board side panel	panneaux lateraux boite a bornes	seitenbleche klemmkasten	panel lateral caja de bornes	9903905803
96	pannello ant. scatola morsettiera	terminal board front panel	panneaux avant boite a bornes	vorderes blechklemmkasten	panel anterior caja de bornes	9903905802
97	pannello post. scatola morsettiera	terminal board rear panel	panneaux arriere boite a bornes	seitenbleche klemmkasten	panel posterior caja de bornes	9903905804
98	pannello porta regolatore	regulator carrying panel	panneau blocage disques	deffnungsblech fuer regler	panel portaregolator	9903905414
99	anello bloccaggio dischi	disc locking ring-spacer	anneau blocage des disques	spannungr distanzscheiben	anillo de bloc. discos separadores	6110611520
138A	tubetto ingrassatore posteriore	rear greasing pipe	tube graisseur arriere	hintere schmierpresse	tubo engrasador posterior	9911147025
138B	tubetto ingrassatore ant. B34	front B34 greasing pipe	tube graisseur avant B34	vordere B34 schmierpresse	tubo engrasador anterior B34	9911945250
139	basetta morsettiera	terminal strip	planchette à bornes	klemmenbrett	placa bornes	7501210030
140	morsetto in rame	copper terminal	borne en cuivre	kupfer klemme	borne de cobre	5504010005
141	ponte in rame	copper bridge	pont en cuivre	kupfer brucke	punte de cobre	5504010006
142A	staffa supporto	stirrup support	patte de fixation bonier puissance	steigbugel unterstutzen	placa de soporte	9903905824
142B	staffa supporto	stirrup support	patte de fixation bonier puissance	steigbugel unterstutzen	placa de soporte	9903905825

N.B.- Nella richiesta di pezzi di ricambio specificare il tipo e il codice dell'alternatore.

When requesting spare parts always indicate the alternator's type and code.

Pour toute demande de pièces détachées, prière de mentionner le type et le code de l'alternateur.

Bei Ersatzteilbestellung bitte immer die Teilbenennung den Typ und den code des Wechselstromgenerators angeben.

En cada pedido de piezas de recambio especificar siempre el tipo y el código del alternador.